

# AUDCO Plug Valves

## Cast Iron

### Regular Pattern - Standard Type

AUDCO Lubricated Taper Plug Valve has been successfully used in a variety of services because of its unique in-line maintenance capability. The Plug and Body seating surfaces, which are lapped and matched, are not exposed to the line fluid; this confines corrosion and erosion to less critical areas. Sealing is further enhanced by a specially developed plug sealant charged evenly around the seating surfaces. Plugs from 1½" are impregnated with a PTFE based anti-friction agent - 'SUPER LoMu' which provides greater wear resistance and ensures low consistent operating torque. SUPER LoMu also enhances resistance to seizure.

#### OPERATION

Regular pattern Cast Iron Lubricated Taper Plug Valves are supplied with square stems suitable for wrench operation (MW series). Valves 4" and above can be offered with Light Duty Gear Units (MO series). Valves 6" and above can be offered with Heavy Duty Worm Gear Unit (MG series). Wrenches and Gear units should be selected as determined by the service conditions, which influence the operating torque. However wrenches should be ordered separately whereas gear units as ordered are installed on the valves and supplied. Valves can also be offered with Carbon Steel Plug (MWS/MOS/MGS series).

As a standard, Cast Iron Valves are supplied with AUDCO 731 Plug sealant which is suitable for most services other than acid solutions and petroleum products. On request, plug sealant from a wide range offered, can be supplied to suit the nature of service. It is recommended that you consult us before selecting the plug sealant for a new service.

#### END CONNECTIONS

Valves can be offered with screwed ends and flanged ends to the following standards.

Screwed : BSP Tr as per BS21 & NPT as per ANSI/ASME B1.20.1.

Flanged : To match flanges drilled to BS10 Table D, F and ANSI/ASME B16.1, Class 125.

Drilling to DIN 2532 PN10 or BS 10 Table E or BS 4504 PN 10 can be offered.

Valves can also be offered with undrilled flanges.

#### MATERIAL SPECIFICATION

Name of Part	Specification
Body Cover & Gland	Cast Iron IS 210 Gr. FG220
Plug	Cast Iron IS 210 Gr. FG 220 or Carbon steel ASTM A216 Gr. WCB
Bolting	Carbon Steel Studs : BS970 220 M07 Hex. Screw : ANSI B18.2.1 Hex. Nut : ANSI B18.2.2
Shim	Mild Steel, Nickel Plated
Gland Packing	Rubberised Asbestos
Gasket	Compressed Asbestos

#### CATALOGUE NUMBER

A familiarity with our Catalogue number is not necessary when specifying our Valves. Provide the following details of the valve to our Distributor/Stockist: Size, Type (Standard, Inverted), Line Fluid, Pattern, Materials of construction, Pressure rating, End connection and Type of Operation.

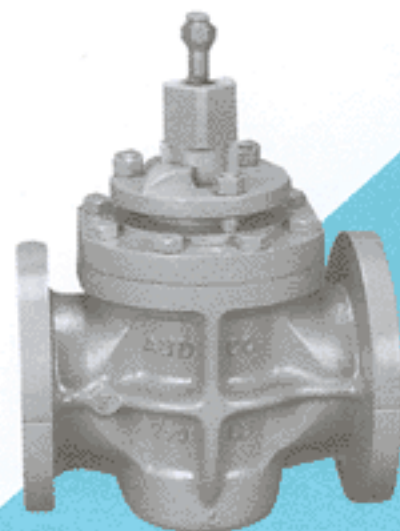

## TECHNICAL DATA

Catalogue No.	End Connection	Max C.W.P.		Test Pressure (psig)	
		psig	bar	Body	Seat
MW12	Screwed BSP Tr	150	10	225	165
MW14	Screwed NPT	200	14	300	220
MW/MWS/MO/MOS/MG/MGS 11	Flanged BST 'D'	100	7	225	165
MW/MWS/MO/MOS/MG/MGS 11F	Flanged BST 'F'	150	10	225	165
MW/MWS/MO/MOS/MG/MGS 13	Flanged Class 125	200	14	300	220

Test pressure for body and seat including duration of test conforms to BS 6755 Part I.

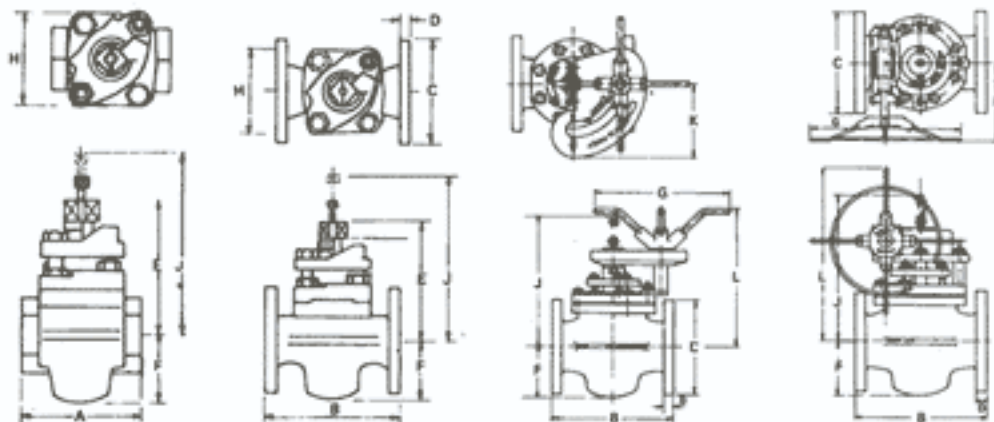

## DIMENSIONS (mm)

Size	1/2" DN 15	3/4" DN 20	1" DN 25	1.1/4" DN 32	1.1/2" DN 40	2" DN 50	2.1/2" DN 65	3" DN 80	4" DN 100	5" DN 125	6" DN 150	8" DN 200	
End to End	Screwed A	88.9	95.3	111.3	127.0	133.4	152.4	222.3	241.3	304.8	355.6	393.7	457.2
Face to Face	Flanged B	120.7	120.7	139.7	152.4	165.1	203.2	222.3	241.3	304.8	355.6	393.7	457.2
Flange diameter	BST 'D' C	95.3	101.6	120.7	120.7	133.4	152.4	165.1	184.2	215.9	254.0	279.4	336.6
	BST 'F'	95.3	101.6	120.7	133.4	139.7	165.1	184.2	203.2	228.6	279.4	304.8	368.3
	CL. 125	95.3	98.6	108.0	117.3	127.0	152.4	177.8	190.5	228.6	254.0	279.4	342.9
Flange thickness	BST 'D' D	12.7	12.7	12.7	15.7	15.7	19.1	19.1	19.1	22.4	23.8	25.4	28.4
	BST 'F'	12.7	12.7	12.7	15.7	15.7	19.1	19.1	19.1	23.9	25.4	25.4	28.4
	CL. 125	12.7	12.7	12.7	15.7	15.7	19.1	19.1	19.1	23.9	23.8	25.4	28.4
C/L to top of plug	E	114	114	121	121	155	173	202	227	248	295	327	402
C/L to bottom of body	F	46	46	49	49	65	76	102	108	137	164	186	232
H/W diameter	G									578	578	578	
Max. width	H	102	102	85	85	104	127	138	149	219	260	289	349
Clearance	MW/MO J	154	168	175	175	213	249	273	308	354	416	449	524
	M G										495	573	
C/L to Quadrant	MO K								229	229	229	229	
C/L to H/W face	MG										308	308	
C/L to top of H/W	MO L								384	432	457	516	
	MG										619	686	
Wrench No.		3H/2H*	3H	3H	3H	4H	5H	6H	7H	8H	10H	10H+	
Sealant stick size		A	A	A	A	B	C	C	D	D	E	E	E

\* For 1/2" MW 12 the wrench will be 2H + Light duty unit is recommended for valve size 6"

As we continuously endeavour to improve our products, the data given herein are subject to change.

### Manufactured & Marketed by:

FLOWERVE INDIA CONTROLS PVT LTD – MMN PLANT

B-8, MMDA Industrial Area, Maraimalai Nagar,

Kanchipuram Dist – 603 209 Tamil Nadu, India

Phone : +91 44 2745 2323 Fax : +91 44 2742 2327

Email : [AudcoPlugindia@flowserve.com](mailto:AudcoPlugindia@flowserve.com)

[AudcoSlimsealindia@flowserve.com](mailto:AudcoSlimsealindia@flowserve.com)

# AUDCO Plug Valves

## Cast Iron

### Short Pattern - Standard Type

AUDCO Lubricated Taper Plug Valve has been successfully used in a variety of services because of its unique in line maintenance capability. The Plug and Body seating surfaces, which are lapped and matched, are not exposed to the line fluid; this confines corrosion and erosion to less critical areas. Sealing is further enhanced by a specially developed plug sealant charged evenly around the seating surfaces. Plugs are impregnated with a PTFE based anti-friction agent - 'SUPER LoMu' which provides greater wear resistance and ensures low consistent operating torque. SUPER LoMu also enhances resistance to seizure.

#### OPERATION

Short Pattern Lubricated Taper Plug Valves upto 10" are all supplied with square stems suitable for wrench operation (LW Series). Valves 6" to 10" can be offered with Light Duty Gear Units (LO Series). Valves 6" and above can be offered with Heavy Duty Worm Gear Unit (LG Series). Wrenches and Gear Units should be selected as determined by the service conditions, which influence the operating torque. However wrenches should be ordered separately whereas gear units as ordered are installed on the valves and supplied. Valves can also be offered with Carbon Steel Plug (LWS/LOS/LGS Series)

As a standard, Cast Iron Plug Valves are supplied with AUDCO 731 Plug sealant which is suitable for most services other than acid solutions and petroleum products. On request, plug sealant from a wide range offered, can be supplied to suit the nature of service. It is recommended that you consult us before selecting the plug sealant for a new service.

#### END CONNECTIONS

Valves can be offered with flanged ends to the following standards.

Flanged : To match flanges drilled to BS10 Table D and ANSI/ASME B16.1, Class 125.

Drilling to DIN 2532 PN 10 or BS 4504 PN 10 can be offered

Valves can also be offered with undrilled flanges.

Sizes 6" and above have some holes (refer table) tapped on each flange to facilitate fastening of the mating flanges and require studs of same diameter of the bolts which they replace. The tapping is to UNC threads of class 125 & BST 'D' flanges and ISO metric coarse for PN10 flanges.

#### MATERIAL SPECIFICATION

Name of Part	Specification
Body Cover & Gland	Cast Iron IS 210 Gr. FG 220
Plug	Cast Iron IS 210 Gr. FG 220 or Carbon steel ASTM A216 Gr. WCB
Bolting	Carbon Steel Studs : BS 970 220 M07 Hex. Screw : ANSI B18.2.1 Hex. Nut : ANSI B18.2.2
Shim	Mild Steel, Nickel Plated
Gland Packing	Rubberised Asbestos
Gasket	Compressed Asbestos

#### CATALOGUE NUMBER

A familiarity with our Catalogue number is not necessary when specifying our Valves.

Provide the following details of the valves to our Distributor/Stockist:- Size, Type (Standard, Inverted), Line Fluid, Materials of construction (Body, Plug), Pressure Rating, End Connection, Type of Operation.



## TECHNICAL DATA

Catalogue No.	End Connection	Max C.W.P.		Test Pressure (psig)	
		psig	bar	Body	Seat
LW11/LWS11/LO11/LOS11/LG11/LGS11	Flanged BST 'D'	100	7	225	165
LW13/LWS13/LO13/LOS13/LG13/LGS13	Flanged Class 125	200	14	300	220

Test Pressure for body and seat including duration of test conforms to BS 6755 Part I

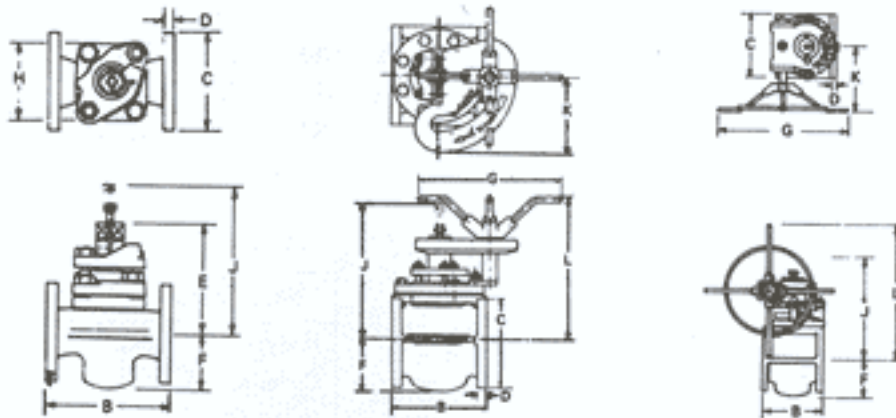

## DIMENSIONS (mm)

Size		2" DN50	2.1/2" DN65	3" DN80	4" DN100	6" DN150	8" DN200	10" DN250	12" DN300
Face to Face	B	177.8	190.5	203.2	228.6	266.7	292.1	330.2	355.6
Tapped Hole details per flange	BST 'D'	-	-	-	-	2 x 5/8" 22mm deep	4 x 5/8" 28mm deep	4 x 3/4" 30mm deep	8 x 3/4" 32mm deep
	CL.125	-	-	-	-	2 x 3/4" 22mm deep	2 x 3/4" 28mm deep	2 x 7/8" 30mm deep	2 x 7/8" 32mm deep
Flange diameter	BST 'D'	152.4	165.1	184.2	215.9	279.4*	342.9*	406.4*	482.6*
	CL.125	152.4	177.8	190.5	228.6	279.4	342.9	406.4	482.6
Flange thickness	D	19.1	19.1	19.1	23.9	25.4	28.4	30.2	31.8
C/L to top of plug	E	156	173	202	227	292	327	364	-
C/L to bottom of body	F	71	87	102	114	175	179	219	289
H/W diameter	G	-	-	-	-	578	578	578	578
Max. width	H	105	125	145	152	279	343	381	-
Clearance	LW/LO	J	213	252	278	416	449	483	-
	LG	J	-	-	-	-	486	536	597
C/L to Quadrant/ H/W face	LO	K	-	-	-	229	229	229	-
	LG	K	-	-	-	-	308	308	308
C/L to top of H/W	LO	L	-	-	-	432	457	508	-
	LG	L	-	-	-	-	616	679	718
Wrench No.		4H	5H	6H	7H	10H	10H+	10H+	-
Sealant stick size		B	C	C	D	E	E	E	E

\* These valves have flanges integral with the body and Class 125 diameter.

+ Light duty gear unit is recommended for Valves sizes 8" & 10"

As we continuously endeavour to improve our products, the data given herein are subject to change.

### Manufactured & Marketed by:

FLOWSERVE INDIA CONTROLS PVT LTD – MMN PLANT

B-8, MMMA Industrial Area, Maraimalai Nagar,

Kanchipuram Dist – 603 209 Tamil Nadu, India

Phone : +91 44 2745 2323 Fax : +91 44 2742 2327

Email : [AudcoPlugindia@flowserve.com](mailto:AudcoPlugindia@flowserve.com)

[AudcoSlimsealindia@flowserve.com](mailto:AudcoSlimsealindia@flowserve.com)

# AUDCO Plug Valves

## Cast Iron

### Regular Pattern - Inverted Type

AUDCO Lubricated Taper Plug Valve has been successfully used in a variety of services because of its unique in-line maintenance capability. The Plug and Body seating surfaces, which are lapped and matched, are not exposed to the line fluid; this confines corrosion and erosion to less critical areas. Sealing is further enhanced by a specially developed plug sealant, charged evenly around the seating surfaces. Plugs are impregnated with a PTFE based anti-friction agent - 'SUPER LoMu' which provides greater wear resistance and ensures low consistent operating torque. SUPER LoMu also enhances resistance to seizure.

#### OPERATION

Regular pattern Inverted Cast Iron Lubricated Taper Plug Valves are all supplied with worm gear units (BG series). Valves can also be offered with Carbon Steel Plug (BGS series).

As a standard, Cast Iron Valves are supplied with AUDCO 731 Plug sealant which is suitable for most services other than acid solutions and petroleum products. On request, plug sealant from a wide range offered, can be supplied to suit the nature of service. It is recommended that you consult us before selecting the plug sealant for a new service.

#### END CONNECTIONS

Valves can be offered with flanged ends to the following standards.

Flanged : To match flanges drilled to BS10 Table D, F and ANSI/ASME B16.1 Class 125

Drilling to DIN 2532 PN10 or BS 4504 PN 10 can be offered

#### CATALOGUE NUMBER

A familiarity with our Catalogue number is not necessary when specifying our valves.

Provide the following details of the valve to our Distributor/Stockist:

- Size
- Type (Standard, Inverted)
- Line Fluid
- Pattern (Regular, Venturi, Short)
- Materials of construction (Body, Plug)
- Pressure Rating
- End Connection & Type of Operation

#### MATERIAL SPECIFICATION

Name of Part	Specification
Body & Gland	Cast Iron IS 210 Gr. FG 220
Cover	Carbon Steel - ASTM A216 Gr. WCB/IS: 2062
Plug	Cast Iron IS 210 Gr. FG 220 or Carbon Steel ASTM A216 Gr. WCB
Bolting Studs Hex. Screw/ Hex. Nut	Carbon Steel BS: 970 220 M07 ANSI B18.2.1/ ANSI B18.2.2
Gland Packing	Rubberised Asbestos
Gasket	Compressed Asbestos

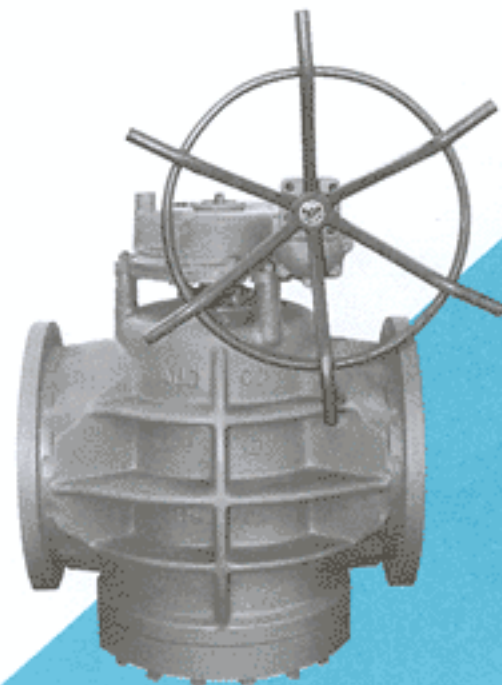

## TECHNICAL DATA

Catalogue No.	End Connection	Max C.W.P.		Test Pressure (psig)	
		psig	bar	Body	Seat
BG11/BGS11 BG11F/BGS11F BG13/BGS13	Flanged BST 'D'	100	7	225	165
	Flanged BST 'F'	150	10	225	165
	Flanged Class 125 — Size 12"	200	14	300	220
	— Size 14"-18"	150	10	225	165

Test pressure for body and seat including duration of test conforms to BS 6755 Part 1

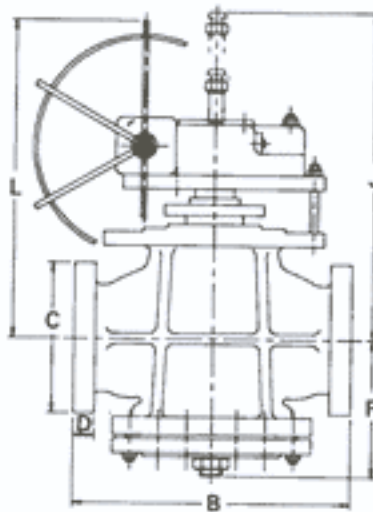
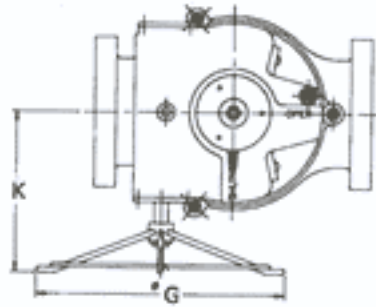

## DIMENSIONS (mm)

Valve Size		12" DN 300	14" DN 350	16" DN 400	18" DN 450
Face to Face	B	609.6	609.6	685.8	863.6
Flange Diameter	BST 'D'	457.2	527.1	577.9	641.4
	BST 'F'	489.0	552.5	609.6	673.1
	Class 125	482.6	533.4	596.9	635.0
Flange thickness	D	31.8	35.1	36.6	39.7
C/L to bottom of body	F	349	375	416	489
H/W diameter	G	787	787	787	787
Clearance	J	654	649	702	703
C/L to H/W face	K	437	437	437	529
C/L to top of H/W	L	862	851	899	992
Sealant stick size		E	E	E	E

As we continuously endeavour to improve our products, the data given herein are subject to change.

### Manufactured & Marketed by:

FLOWSERVE INDIA CONTROLS PVT LTD – MMN PLANT

B-8, MMDA Industrial Area, Maraimalai Nagar,  
Kanchipuram Dist – 603 209 Tamil Nadu, India

Phone : +91 44 2745 2323 Fax : +91 44 2742 2327

Email : [AudcoPlugindia@flowserve.com](mailto:AudcoPlugindia@flowserve.com)

[AudcoSlimsealindia@flowserve.com](mailto:AudcoSlimsealindia@flowserve.com)

# AUDCO Plug Valves

## Steam Jacketed

Cast Iron & Carbon Steel,  
Regular & Venturi Pattern - Standard Type

AUDCO Lubricated Taper Plug Valve has been successfully used in a variety of services because of its unique in line maintenance capability. The Plug and Body seating surfaces, which are lapped and matched, are not exposed to the line fluid; this confines corrosion and erosion to less critical areas. Sealing is further enhanced by a specially developed plug sealant charged evenly around the seating surfaces. Plugs from 1½" are impregnated with a PTFE based anti-friction agent - 'SUPER LoMu' which provides greater wear resistance and ensures low consistent operating torque. SUPER LoMu also enhances resistance to seizure.

Steam jacketed valves have an integral chamber around the body. The chamber is provided with inlet and outlet screwed connections for passing steam. This feature helps to keep the line fluid heated and prevents solidification inside the valve.

### OPERATION

Steam Jacketed Lubricated Taper Plug Valves are all supplied with square stems suitable for wrench operation (MJ/MWJ/KWJ Series). Wrenches, as required, should however be ordered separately. 6" valves can be offered with Heavy Duty Worm Gear Unit (KGJ Series). Wrenches and Gear Units should be selected as determined by the service conditions, which influence the operating torque. Gear Units as ordered are installed on the valves and supplied.

Cast Iron Valves (MJ Series) and Carbon Steel Valves (MWJ Series) of sizes upto 4" are of Regular Pattern. Carbon Steel Valve (KWJ/KGJ Series) of size 6" is of Venturi Pattern.

As a standard, Steam Jacketed Valves are supplied with AUDCO 731 Plug sealant which is suitable for most services other than acid solutions and petroleum products. On request, plug sealant from a wide range offered, can be supplied to suit the nature of service. It is recommended that you consult us before selecting the plug sealant for a new service.

### END CONNECTIONS

Valves can be offered with flanged ends to the following standards.

- Cast Iron Valves:** BS10 Table D and F ANSI/ASME B16.1 Class 125.  
Drilling to DIN 2523 PN 10, BS 4504 PN 10, BS 10 Table E or undrilled flanges can also be offered.
- Carbon Steel Valves:** ANSI/ASME B16.5 Class 300 RF, spirally serrated.  
Drilling to DIN 2545 PN 40 or BS 4504 PN40 can be offered.

### CATALOGUE NUMBER

A familiarity with our Catalogue number is not necessary when specifying our Valves.

Provide the following details of the valves to our Distributor/Stockist:- Size, Type, Line Fluid,

Materials of construction, Pressure Rating, End Connection and Type of Operation.

### MATERIAL SPECIFICATION

Name of Part	Specification	
	MJ 11/11F13	MWJ/KWJ/KGJ33
Body	Cast Iron IS210 Gr. FG220	Carbon Steel, ASTM A 105 upto 1" ASTM A 216 Gr. WCB for sizes 1½" & above
Cover, Gland & Plug	Cast Iron IS 210 Gr. FG 220	ASTM A216 Gr WCB/ IS:2062
Bolting Studs Hex. Screw/ Hex. Nut	Carbon Steel BS:970 220 M07 ANSI B18.2.1 ANSI B18.2.2	Alloy Steel. ASTM A 193 Gr. B7 & A 194 Gr. 2H
Shim	Mild Steel, Nickel Plated	
Gland packing	Rubberised Asbestos	
Gasket	Compressed Asbestos	



## TECHNICAL DATA

Catalogue No.	End Connection	Max C.W.P.		Test Pressure (psig)	
		psig	bar	Body	Seat
MJ11	Flanged BST'D'	100	7	225	165
MJ11F	Flanged BST'F'	150	10	225	165
MJ13	Flanged Class 125	200	14	300	220
MWJ33/KWJ33/KGJ33	Flanged Class 300 RF	740	51	1125	815

Maximum Working pressure recommended in Jacket-125 psig.

Test pressure for body and seat including duration of test conforms to BS 6755 Part I

## DIMENSIONS (mm)

Size	1" DN25	1.1/2" DN40	2" DN50	3" DN80	4" DN100	6" DN150
Face to Face MJ MWJ/KWJ/KGJ	B 139.7 158.8	165.1 190.5	203.2 215.9	241.3 282.4	355.6 304.8	403.4
Flange diameter BST'D' BST'F' CL. 125 CL. 300	C 120.7 120.7 108.0 124.0	133.4 139.7 127.0 155.4	152.4 165.1 152.4 165.1	184.2 203.2 190.5 209.6	215.9 228.6 228.6 254.0	317.5
Flange thickness MJ MWJ/KWJ/KGJ	D 12.7 17.5	15.7 20.6	19.1 22.4	19.1 28.4	23.8 31.8	36.6
CL/to top of plug MJ MWJ/KWJ	E 121 117	155 152	173 176	227 230	248 246	282
C/L to bottom of body MJ MWJ KWJ/KGJ	F 75 51 -	97 65 -	114 81 -	143 114 -	178 140 -	159
H/W diameter	G	-	-	-	-	578
Max. width MJ MWJ KWJ	H 105 78 -	130 105 -	162 125 -	183 152 -	229 219 -	441
Clearance MJ MWJ/KWJ KGJ	J 175 170 -	213 210 -	249 265 -	318 325 -	338 343 -	403 468
C/L to H/W face KGJ	K	-	-	-	-	308
C/L to top KGJ	L	-	-	-	-	589
Size of Jacket connections	3/4" BSP Tr	1" BSP Tr	1.1/4" BSP Tr	1.1/4" BSP Tr	1.1/2" BSP Tr	3/4" NPT
No. of Jacket connections	3	3	3	3	5	3
Positions of Jacket connections	IR IL	IR IL	IR IL	IR IL	6R 6L 4R 4L	IR IL
	9	9	9	9	9	9
Wrench No.	3H	4H	5H	7H	8H	10H
Sealant Stick Size	A	B	C	D	D	E

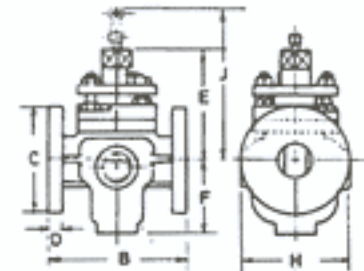

Sizes 1" - 6"  
Wrench operation

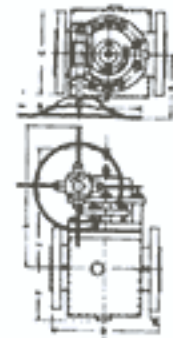

Size 6"  
Worm gear unit operation

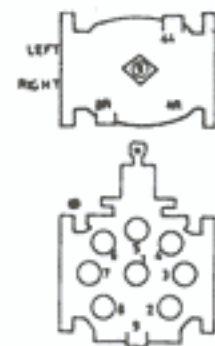

Positions of  
Jacket Connections

1/16" raised face height is included in face to face dimension and flange thickness of Carbon Steel Valves

As we continuously endeavour to improve our products, the data given herein are subject to change.

### Manufactured & Marketed by:

FLOWERVE INDIA CONTROLS PVT LTD – MMN PLANT

B-8, MMDA Industrial Area, Maraimalai Nagar,

Kanchipuram Dist – 603 209 Tamil Nadu, India

Phone : +91 44 2745 2323 Fax : +91 44 2742 2327

Email : [AudcoPlugindia@flowserve.com](mailto:AudcoPlugindia@flowserve.com)

[AudcoSlimsealindia@flowserve.com](mailto:AudcoSlimsealindia@flowserve.com)

# AUDCO Plug Valves

## AUDCOLOY

### Regular & Short Pattern - Standard Type

AUDCO Lubricated Taper Plug Valves have been successfully used in a variety of services because of its unique in line maintenance capability. The Plug and Body seating surfaces, which are lapped and matched, are not exposed to the line fluid; this confines corrosion and erosion to less critical areas. Sealing is further enhanced by a specially developed plug sealant charged evenly around the seating surfaces. Plugs from 1½" are impregnated with a PTFE based anti-friction agent - 'Super LoMu' which provides greater wear resistance and ensures low consistent operating torque. SUPER LoMu also enhances resistance to seizure.

#### OPERATION

Audcoloy Lubricated Taper Plug Valves upto 8" are all supplied with square stems suitable for wrench operation (MD Series). Wrenches, as required, should be ordered separately. Valves 4" to 8" can be offered with Light Duty Gear Units (MDO Series). Valves 6" and above can be offered with Heavy Duty Worm Gear Unit (MDG/LDG Series). Wrenches and Gear Units should be selected as determined by the service conditions, which influence the operating torque. Gear Units as ordered are installed on the valves and supplied.

Valves upto 8" are of Regular Pattern (MD series) and 10" & 12" are of Short Pattern (LDG series).

As a standard, Audcoloy Plug Valves are supplied with AUDCO 147 Plug sealant which is suitable for services like nitrating acids, sulphuric acid and oxidizing chemicals. On request, plug sealant from a wide range offered, can be supplied to suit the nature of service. It is recommended that you consult us before selecting the plug sealant for a new service.

#### END CONNECTIONS

Valves can be offered with screwed ends and flanged ends to the following standards.

Flanged : To match flanges drilled to BS 10 Table D, F and ANSI/ASME B16.1, Class 125.

Drilling to DIN 2532 PN 10, BS 4504 RN 10 or BS 10 Table E can be offered.

Valves can also be offered with undrilled flanges.

#### MATERIAL SPECIFICATION

Name of Part	Specification
Body &	Audcoloy
Cover & Gland	Cast Iron IS 210 Gr. FG 220
Plug	Audcoloy
Bolting Studs Hex. Screws Hex. Nuts	Carbon Steel BS 970 220 M07 ANSI B18.2.1 ANSI B18.2.2
Shim	Stainless Steel, AISI 304
Gland Packing	Rubberised Asbestos
Gasket	Compressed Asbestos

Audcoloy' is an austenitic alloy cast iron as per BS3468 Grade AUS 104.

#### CATALOGUE NUMBER

A familiarity with our Catalogue number is not necessary when specifying our valves.

Provide the following details of the valves to our Distributor/Stockist:- Size, Type (Standard, Inverted), Line Fluid, Materials of construction (Body, Plug), Pressure Rating, End Connection, Type of Operation.



## TECHNICAL DATA

Catalogue No.	End Connection	Max C.W.P.		Test Pressure (psig)	
		psig	bar	Body	Seat
MD11/MD011/MDG11/LDG11	Flanged BST 'D'	100	7	225	165
MD11F/MD011F/MDG11F	Flanged BST 'F'	150	10	225	165
MD13/MD013/MDG13/LDG13	Flanged Class 125	200	14	300	220

Test pressure for body and seat including duration of test conforms to BS 6755 Part 1

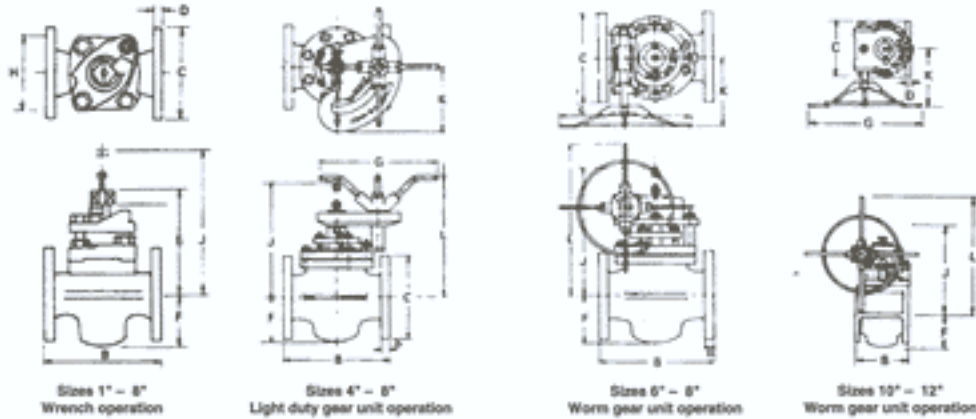

## DIMENSIONS (mm)

Size	1" DN25	1.1/2" DN40	2" DN50	2.1/2" DN65	3" DN80	4" DN100	5" DN125	6" DN150	8" DN200	10" DN250	12" DN300
Face to Face B	139.7	165.1	203.2	222.3	241.3	304.8	355.6	393.7	457.2	330.2	355.6
No. of tapped holes per flange BST 'D' CL. 125										4 2	8 2
Flange Diameter BST 'D' BST 'F' CL. 125	C 120.7 120.7 108.0	133.4 139.7 127.0	152.4 165.1 152.4	165.1 184.2 177.8	184.2 203.2 190.5	215.9 228.6 228.6	254.0 279.4 254.0	279.4 304.8 279.4	336.6 368.3 342.9	406.4 - 406.4	482.6 - 482.6
Flange thickness BST 'D' BST 'F' CL. 125	D 12.7 12.7 12.7	15.7 15.7 15.7	19.1 19.1 19.1	19.1 19.1 19.1	19.1 19.1 19.1	22.4 23.9 23.9	23.8 25.4 23.8	25.4 25.4 25.4	28.4 28.4 28.4	30.2 - 30.2	31.8 - 31.8
C/L to top of plug E	121	155	173	202	227	248	295	327	402	-	-
C/L to bottom of body F	49	65	76	102	108	137	164	186	232	219	289
H/W Diameter G						578	578	578	578	578	578
Max. width H	85	104	127	138	149	219	260	289	349	-	-
Clearance MD/MDO MDG LDG	J 175	213	249	273	308	354	416	449 495	524 573	- 536	- 597
C/L to quadrant/ H/W face MDO MDG LDG	K					229	229	229 308	229 308	- 308	- 308
C/L to top of H/W MDO MDG LDG	L					384	432	457 619	516 686	679	718
Wrench No.	3H	4H	5H	6H	7H	8H	10H	10H+			
Sealant Stick size	A	B	C	C	D	D	E	E	E	E	E

+ Light duty gear unit is recommended for Valves size 6".

As we continuously endeavour to improve our products, the data given herein are subject to change.

### Manufactured & Marketed by:

FLOWERVE INDIA CONTROLS PVT LTD – MMN PLANT

B-8, MMDA Industrial Area, Maraimalai Nagar,

Kanchipuram Dist – 603 209 Tamil Nadu, India

Phone : +91 44 2745 2323 Fax : +91 44 2742 2327

Email : [AudcoPlugindia@flowserve.com](mailto:AudcoPlugindia@flowserve.com)

[AudcoSlimsealindia@flowserve.com](mailto:AudcoSlimsealindia@flowserve.com)

# AUDCO Plug Valves

## Carbon Steel

### Class 150 - Short Pattern - Standard Type

AUDCO Lubricated Taper Plug Valve has been successfully used in a variety of services because of its unique in-line maintenance capability. The Plug and Body seating surfaces, which are lapped and matched, are not exposed to the line fluid; this confines corrosion and erosion to less critical areas. Sealing is further enhanced by a specially developed plug sealant, charged evenly around the seating surfaces. Plugs are impregnated with a PTFE based anti-friction agent - 'SUPER LoMu' which provides greater wear resistance and ensures low consistent operating torque. SUPER LoMu also enhances resistance to seizure.

#### OPERATION

Short Pattern Carbon Steel Lubricated Taper Plug Valves upto 8" are all supplied with square stems suitable for wrench operation (LW Series). Wrenches, as required, should however be ordered separately. Valves 6" to 10" can be offered with Light Duty Gear Units (LO Series). Valves 6" and above can also be offered with Heavy Duty Worm Gear Unit (LG Series). Wrenches and Gear Units should be selected as determined by the service conditions, which influence the operating torque. Gear Units as ordered are installed on the valves and supplied.

Valves can also be offered with Carbon Steel Plug (LS/LOS/LGS Series)

As a standard, Carbon Steel Plug Valves are supplied with AUDCO 733 Plug sealant which is suitable for most hydrocarbon services. On request, plug sealant from a wide range offered, can be supplied to suit the nature of service. It is recommended that you consult us before selecting the plug sealant for a new service.

#### END CONNECTIONS

Valves can be offered with flanged ends to the following standards.

Flanged: To match flanges drilled to ANSI/ASME B16.5 Class 150 RF, spirally serrated.

Drilling to DIN 2543 PN 16 or BS 4504 PN 16 can be offered.

Sizes 6" and above have some holes (refer table) tapped on each flange to facilitate fastening of the mating flanges and require studs of same diameter of the bolts which they replace. The tapping is to UNC threads for ANSI Class 150 flanges and ISO metric coarse for PN 16 flanges.

#### MATERIAL SPECIFICATION

Name of Part	Specification	
	LW/LO/LG-23	LS/LOS/LGS-23
Body	Carbon Steel ASTM A216 Gr.WCB	
Cover & Gland	Carbon Steel - ASTM A216 Gr. WCB/IS: 2062	
Plug	Cast Iron IS 210 Gr. FG 220	Carbon steel ASTM A216 Gr. WCB
Bolting Studs Hex. Screw/ Hex. Nut	Carbon Steel BS: 970 220 N07 ANSI B18.2.1/ ANSI B18.2.2	Alloy Steel ASTM A193 Gr. B7 & ASTM A194 Gr.2H
Shim	Mild Steel, Nickel Plated	
Gland Packing	Rubberised Asbestos	
Gasket	Compressed Asbestos	

#### CATALOGUE NUMBER

A familiarity with our Catalogue number is not necessary when specifying our Valves.

Provide the following details of the valve to our Distributor/Stockist:

- Size
- Type (Standard, Inverted)
- Line Fluid
- Pattern (Regular, Venturi, Short)
- Materials of construction (Body, Plug)
- Pressure Rating
- End Connection & Type of Operation



## TECHNICAL DATA

Catalogue No.	End Connection	Max C.W.P.		Test Pressure (psig)	
		psig	bar	Body	Seat
LW23/LS23/LO23/LOS23/LG23/LGS23	Flanged Class 150 RF	285	20	450	315

Test pressure for body and seat including duration of test conforms to BS 6755 Part I

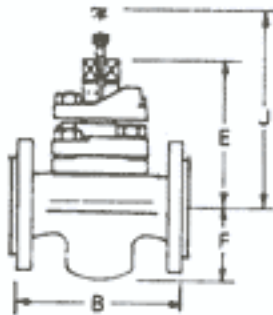
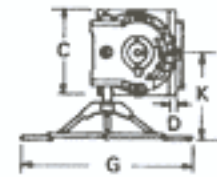
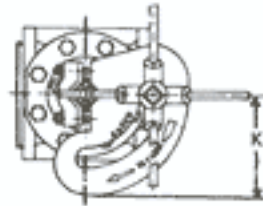
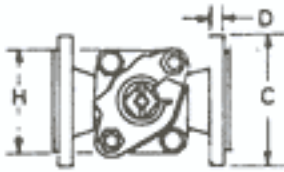

Sizes 2" – 8"  
Wrench operation

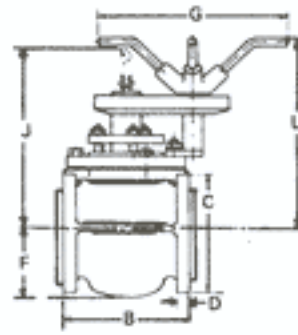

Sizes 6" – 10"  
Light duty gear unit operation

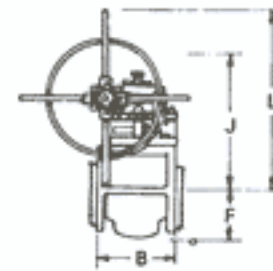

Sizes 6" – 12"  
Worm gear unit operation

## DIMENSIONS (mm)

Size		2" DN 50	3" DN 80	4" DN 100	6" DN 150	8" DN 200	10" DN 250	12" DN 300	
Face to Face	B	177.8	203.2	228.6	266.7	292.1	330.2	355.6	
Tapped Hole details per flange		–	–	–	2 x 3/4" 22 mm deep	4 x 3/4" 27 mm deep	4 x 7/8" 30 mm deep	8 x 7/8" 32 mm deep	
Flange diameter - Class 150	C	152.4	190.5	228.6	279.4	342.9	406.4	482.6	
Flange thickness	D	15.7	19.1	23.8	25.4	28.4	30.2	31.8	
C/L to top of plug	E	152	208	230	292	327	364	–	
C/L to bottom of body	F	71	102	114	160	186	216	289	
H/W diameter	G	–	–	–	578	578	578	578	
Max. width	H	108	144	149	279	343	381	–	
Clearance	LW/LO LG	J	226 –	297 –	324 –	414 460	449 486	483 536	– 597
C/L to Quadrant face	LO	K	–	–	–	229	229	229	–
C/L to H/W face	LG	K	–	–	–	308	308	308	338
C/L to top of H/W	LO LG	L	– –	– –	– –	432 597	457 613	508 676	– 718
Wrench No.		4H	6H	7H	10H+	10H+	–	–	
Sealant stick size		B	C	D	E	E	E	E	

+ Light duty gear unit is recommended for Valves sizes 6" & 8". 1.6 mm raised face height is included in face to face dimensions and flange thickness

As we continuously endeavour to improve our products, the data given herein are subject to change.

### Manufactured & Marketed by:

FLOWERVE INDIA CONTROLS PVT LTD – MMN PLANT

B-8, MMMA Industrial Area, Maraimalai Nagar,

Kanchipuram Dist – 603 209 Tamil Nadu, India

Phone : +91 44 2745 2323 Fax : +91 44 2742 2327

Email : [AudcoPlugindia@flowserve.com](mailto:AudcoPlugindia@flowserve.com)

[AudcoSlimsealindia@flowserve.com](mailto:AudcoSlimsealindia@flowserve.com)

## Carbon Steel

### Class 300 - Regular Pattern - Standard Type

AUDCO Lubricated Taper Plug Valve has been successfully used in a variety of services because of its unique in-line maintenance capability. The Plug and Body seating surfaces, which are lapped and matched, are not exposed to the line fluid; this confines corrosion and erosion to less critical areas. Sealing is further enhanced by a specially developed plug sealant, charged evenly around the seating surfaces. Plugs from 1½" are impregnated with a PTFE based anti-friction agent - 'SUPER LoMu' which provides greater wear resistance and ensures low consistent operating torque. SUPER LoMu also enhances resistance to seizure.

#### OPERATION

Regular Pattern Carbon Steel Lubricated Taper Plug Valves are all supplied with square stems suitable for wrench operation (MW series). Wrenches, as required, should however be ordered separately.

As a standard, Carbon Steel Plug Valves are supplied with AUDCO 733 Plug sealant which is suitable for most hydrocarbon services. On request, plug sealant from a wide range offered, can be supplied to suit the nature of service. It is recommended that you consult us before selecting the plug sealant for a new service.

#### END CONNECTIONS

Valves can be offered with screwed ends, flanged ends and socket weld ends to the following standards.

Screwed : BS Tr as per BS21 & NPT as per ANSI/ASME B1.20.1

Flanged : To match flanges drilled to ANSI/ASME B16.5 Class 300 RF, spirally serrated.

Drilling to DIN 2545 PN40 or BS 4504 PN 40 can be offered.

Socketweld: ANSI/ASME B 16.11

#### CATALOGUE NUMBER

A familiarity with our Catalogue numbering is not necessary when specifying our valves.

Provide the following details of the valve to our Distributor/Stockist:

- Size
- Type (Standard, Inverted)
- Line Fluid
- Pattern (Regular, Venturi, Short)
- Materials of construction (Body, Plug)
- Pressure Rating
- End Connection & Type of Operation

#### MATERIAL SPECIFICATION

Name of Part	Specification
Body &	Carbon Steel ASTM A105 for sizes upto 1" ASTM A216 Gr. WCB for sizes 1 ½" & above
Cover	IS 2062
Gland	ASTM A105 or ASTM A216 Gr. WCB
Plug	Carbon Steel - ASTM A216 Gr. WCB or EN 32B
Bolting	Alloy Steel ASTM A193 Gr. B7 & ASTM A194 Gr. 2H
Shim	Mild Steel, Nickel Plated
Gland Packing	Rubberised Asbestos
Gasket	Compressed Asbestos



## TECHNICAL DATA

Catalogue No.	End Connection	Max C.W.P.		Test Pressure (psig)	
		psig	bar	Body	Seat
MW32 MW34 MW33 MW39	Screwed BSP. Tr Screwed NPT Flanged Class 300 RF Socketweld	740	51	1125	815

Test pressure for body and seat including duration of test conforms to BS 6755 Part I

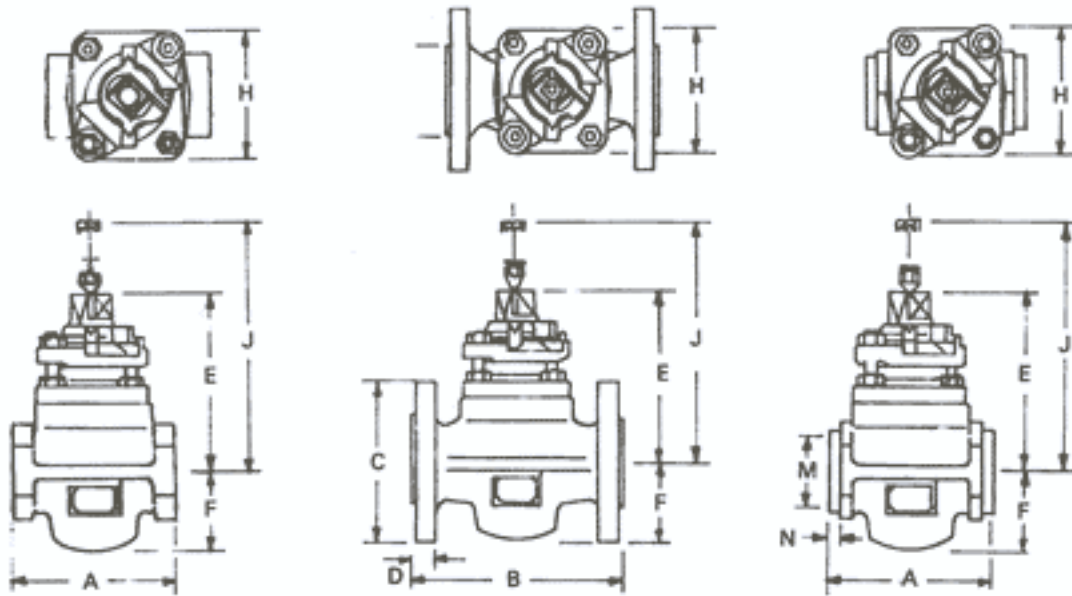

## DIMENSIONS (mm)

Size		1/2" DN15	3/4" DN20	1" DN25	1.1/2" DN40	2" DN50	3" DN80	4" DN100
End to end-Screwed/SW valves	A	95.3	95.3	111.3	133.4	165.1	-	-
Face to Face Flanged valves	B	-	-	158.8*	190.5	215.9	282.4	304.8
Flange diameter	C			124.0	155.4	165.1	209.6	254.0
Flange thickness	D			17.5	20.6	22.4	28.4	31.8
C/L to top of plug	E	100	100	117	152	176	230	246
C/L to bottom of body	F	37	37	51	65	81	114	140
Max. width	H	78	78	78	105	125	152	219
Clearance	J	152	152	170	210	265	325	343
Internal diameter of Socketweld end	M	21.72	27.05	33.78	48.64	61.11	-	-
Depth of socket (not shown)		10	13	13	13	16	-	-
Wrench No.		2H	2H	3H	4H	5H	7H	8H
Sealant stick size		A	A	A	B	C	D	D

1.6 mm raised face height is included in face to face dimensions and flange thickness

\* - Welded on flanges

As we continuously endeavour to improve our products, the data given herein are subject to change.

### Manufactured & Marketed by:

FLOWSERVE INDIA CONTROLS PVT LTD – MMN PLANT

B-8, MMDA Industrial Area, Maraimalai Nagar,

Kanchipuram Dist – 603 209 Tamil Nadu, India

Phone : +91 44 2745 2323 Fax : +91 44 2742 2327

Email : [AudcoPlugindia@flowserve.com](mailto:AudcoPlugindia@flowserve.com)

[AudcoSlimsealindia@flowserve.com](mailto:AudcoSlimsealindia@flowserve.com)